

# LawnMaster®



## 21V LITHIUM **SECATEURS**

### **SAFETY AND OPERATING MANUAL**

PLEASE READ THIS MANUAL CAREFULLY BEFORE OPERATING THE UNIT

## **LB21TT**



A STEELFORT PRODUCT



PROUDLY  
NZ OWNED



## TABLE OF CONTENTS

<b>OPERATOR SAFETY</b>	<b>3</b>
<b>SAFETY RULES</b>	<b>4</b>
<b>FEATURES &amp; TECHNICAL DATA</b>	<b>6</b>
<b>OPERATION</b>	<b>7</b>
Shutdown Operation	
Blade Adjustment & Replacement	
Blade Gap Adjustment	
Blade Disassembly	
Blade Installation	
Grinding & Lubrication of Blades	
Secateurs Precautions	
Alarming Warning	
Installing & Removing Battery	
Battery Indicator	
Charging Method	
<b>MAINTENANCE</b>	<b>10</b>
Side Cover Cleaning	
Inspection for Fixing Screws	
Cleaning	
<b>INSPECTION &amp; REPAIR</b>	<b>10</b>
<b>WARRANTY</b>	<b>11</b>

**Thank you for purchasing our LawnMaster 21V Lithium 2AH Secateurs, the information contained within this manual will help you to have many years of safe and trouble free use of this Lawnmaster product.**

## OPERATOR SAFETY

### SAFETY RULES

This manual contains important safety information and instructions to operate the LawnMaster 21V Lithium Secateurs.

PLEASE READ THIS MANUAL CAREFULLY BEFORE USING THE UNIT.

Failure to adhere to the safety instructions could result in property damage and/or serious personal injury.

This manual should be considered a permanent part of the secateurs and should remain with the unit at all times. All information in this publication is based on the latest product information available at the time of printing.

Product Information and specifications can be altered and/or improved without notice. Content from this publication may not be reproduced without written consent.

### DANGER

Indicates a hazardous situation which, if not strictly complied with, will result in substantial property damage and or serious injury.

### WARNING

Indicates a hazardous situation which, if not strictly complied with, may result in property damage

### CAUTION

Indicates a hazardous situation which, if not strictly complied with, could result in property damage or personal injury.

The warnings and precautions discussed in this manual does not cover all possible conditions and or scenarios that may occur.

It must be understood by the operator that common sense and caution must be taken into consideration when operating this product, as these are factors

which cannot be built into this manual.

### WORKPLACE SAFETY

- Keep the workplace clean and bright to avoid accidents due to messy and dark sites.
- Do not operate power tools in explosive environment, such as those with flammable liquid, gas or dust. Sparks generated in operation may ignite dust or gas.
- When operating power tools, keep away from children and bystanders. Please focus on the operation to avoid losing control of the tools.

### ELECTRIC SAFETY

- Please use well-matched plug and socket. Modified plugs not allowed. Power tools to be grounded shall not use any conversion plug. To reduce the risk of electric shock, please keep the unmodified plugs with matching sockets.
- To avoid shock risks, operators shall not contact with the grounding surfaces, such as pipes, radiators or refrigerators.
- Do not expose power tools to rain or wet environment, which may increase the shock risks.
- Do not abuse wires such as to carry, pull or unplug the power tools. Please keep the wires away from heat, oil, sharp edges or moving parts to avoid shock risks due to damaged or twisted wires.
- When using power tools outdoors, please use extension cords suitable for outdoor use to reduce shock risks.
- If necessary to operate power tools in humid environment, power supply with residual current device (RCD) protection shall be used to avoid shock risks.

NOTE: Term "residual current device (RCD)" equals to "Ground fault circuit interrupter (GFCI)" and "Earth leakage circuit breaker (ELCB)"

### PERSONAL SAFETY

- Stay alert and avoid operating power tools when tired, under the influence of drugs or alcohol, or during medical treatment, as this can lead to serious injury.
- Always wear goggles and, when necessary, use additional protective equipment like dust masks, non-slip safety shoes, safety helmets, and hearing protection to reduce the risk of personal injury.

- Before connecting the power supply or battery pack, picking up, or carrying the tool, ensure the switch is in the off position to prevent accidental starting. Energizing the tool with fingers on the switch or when the switch is on can be extremely dangerous.
- Remove all adjusting keys or wrenches before starting the power tools to avoid personal injury due to their leaving on rotating parts.
- Always pay attention to foothold and body balance without stretching your hand too smoothly to better control the power tools in case of accidents.
- Dress appropriately. Do not wear loose clothes or accessories. Keep your hair and clothes away from moving parts.
- If devices for connecting chip removal and dust collection equipment is provided, please ensure that it is well connected and used properly which will reduce the risk caused by dust.
- Even with frequent tool use and familiarity with their operation, always prioritise safety rules. A single careless action can result in serious injury.
- Do not use power tools for operations that are not compatible with their purpose, please select the tools, accessories and tool heads according to the operating instructions and considering the operating conditions and operations to be carried out to avoid accidents.
- Keep the handle and holding surface dry and clean without grease. In case of accident, the slippery handle can not guarantee the safety of holding and the control of tools.

## SAFETY RULES

### RECHARGEABLE SECATEURSS

- To ensure safety, it is not recommended for individuals with disabilities, mental retardation, inexperience, or limited independent operation ability (including children and minors) to use the tool without supervision. Please closely supervise children to prevent them from regarding the tool as a toy.
- Avoid using a damaged tool, and always inspect the tool and battery pack before each use. If you detect any faults, send the tool to professional personnel for repair; do not attempt to disassemble it yourself. After checking and assembling the tool, keep a safe distance from it and let it run at the highest shear frequency for one minute. This test may reveal most damage in the tool.
- Side-inserted Lithium Secateurs should be equipped with the special BLT-DC16-1865\21700 lithium battery pack, while Balance-pushed Lithium Secateurs should use the special BLT-DC21-18650 lithium battery pack. Only charge the battery pack with the provided tool-specific charger. Avoid using any other battery packs or chargers, including imitations, modifications, or different brands, to prevent personal injury or property damage from potential battery explosions.
- Always hold the insulated handle when operating the tool. The tool's blade may accidentally cut hidden wires. Prior to use, use appropriate detection devices to check for concealed wires or pipes. Cutting a wire can lead to fire and electric shock, damaging a gas pipe can result in an explosion, and cutting a water pipe can cause property damage.
- When operating, maintain a normal step distance and balance; avoid overstretching or leaning your body.

### PRECAUTIONS FOR USING POWER TOOLS

- Choose the right power tools designed for the task at hand to ensure your work is both efficient and safe.
- Do not use the power tools lost control of the switch, which is dangerous and shall be repaired at first.
- To reduce the risk of accidental starting, please remove the plug from the power supply and / or the battery pack (if removable) before any adjustment, replacement of accessories or storage of power tools.
- Please store unused power tools outside the reach of children. People who are not familiar with the operation and instructions shall not use the tools, it's dangerous for untrained users.
- Maintenance of power tools and accessories. Please check whether the moving parts are adjusted in place or stuck, the conditions of damaged parts and others that affecting the operation of electric tools to avoid accidents due to poor maintenance.
- Keep cutting tools sharp and clean. Well maintained tools with sharp cutting edges are not easy to jam and easier to control.

- Ensure you wear safety goggles, non-slip shoes, and gloves, and firmly grip the tools.
- Wear protective gloves, keep your hands away from the switch and the tools powered off when replacing the blade to avoid injury.
- Operate the tool in the correct way to avoid personal injury due to improper operation.
- Use original accessories or accessories provided by the original factory.
- Recycle and reuse damaged machines, Accessories and waste packaging in accordance with local laws and in an environmentally friendly way.
- If the battery pack is overused or overheats, it may leak. Clean or replace contaminated parts as needed. The affected parts and the leaking battery should not be used. If leakage contacts the skin, wash with soap, followed by lemon juice or vinegar. If it comes into contact with the eyes, rinse with clean water and seek immediate medical attention. Battery pack leakage can cause corrosion or burns.
- If the service time of the battery pack is significantly shortened after each charging, please replace it with a new battery pack or go to the maintenance point for inspection.
- The battery pack shall be moisture-proof and mildew proof. Please keep it away from water and rain.
- Please store the battery pack after fully charged.
- The storage ambient temperature range of battery pack is 0-45° Too high or low temperature would affect its capacity.
- Keep the battery pack away from metal objects like paperclips, coins, keys, nails, screws, or other small metal parts, as they can create a connection with the battery pack contacts. Short-circuiting the battery pack contacts can result in sparks, burns, or fires.
- Do not discard the scrapped battery pack in general household waste, flame or water.
- Collect the damaged battery packs and send them to the recycling center for disposal or dispose of them in an environmentally friendly way.
- Do not charge the battery pack when the room temperature is lower than 10° or higher than 50° When the room temperature is lower than 0°, it may not be charged.
- If the lithium secateurs are not used for a long time, it is necessary to fully charge the battery and charge it once every three months for preservation.

## BATTERY PACKS

- Disconnect the switch and remove the battery pack before performing any work, such as changing tools, inspection, maintenance, transportation, storage, etc.
- Ensure that the battery pack is properly installed before using the tool.
- It's a normal phenomenon that the battery pack will become slightly hot during charging.
- Do not charge a damaged battery pack.
- After charging, please cut off the power supply and then unplug the battery pack from the charger. Do not put the battery pack in the charging body for a long time.
- Do not insert the charged battery pack into the charger when the tool is not in use
- Do not attempt to disassemble the battery privately, its maintenance or repair shall be handed over to professional maintenance personnel to avoid danger of electric shock or fire due to incorrect assembly.
- Do not short circuit the battery pack
- Don't burn the battery pack, it will explode in the fire.
- Do not drop, vibrate or impact the battery pack.
- Do not use the battery pack as a hammer. Knocking on the battery pack may cause accidental short circuit, fire or explosion.
- The battery pack must be kept away from high temperature or flame! Do not place it on the heater or expose it to strong sunlight for a long time. High temperature brings a risk of explosion.
- Please keep workplace well ventilated. The toxic gas emitted by the damaged battery pack or that is not used in accordance with the specified requirements may cause personal injury.

**Before using this tool, familiarise yourself with its functions and operating instructions. Stay alert at all times to prevent injury.**

## FEATURES & TECHNICAL DATA

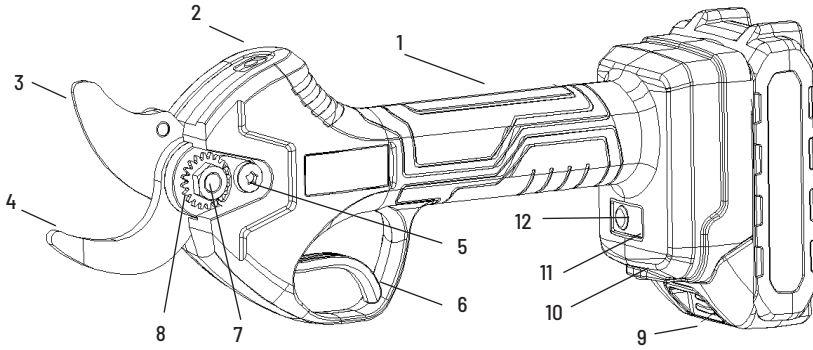

- |                      |                        |                         |
|----------------------|------------------------|-------------------------|
| 1. Handle            | 5. Torx Pan Head Screw | 9. Battery Pack         |
| 2. Failure Indicator | 6. Trigger             | 10. Extension Interface |
| 3. Moving Blade      | 7. Locking Pad         | 11. Battery Indicator   |
| 4. Fixed Blade       | 8. Blade Fixing Nut    | 12. Power Switch        |

MODEL	
Battery	21V 2Ah Lithium
Run Time	3-4 Hours
Charge Time	2.5 Hours
Cutting Length	Hard Branches: 26mm Soft Branches: 32mm
Weight (With Battery)	1.3kg

## OPERATION

**NOTE:** When installing or removing the battery pack, please turn off the power switch and keep away from the blade to avoid accidentally triggering the switch and causing safety problems.

The battery pack is only partially charged when delivered. In order to ensure the maximum power of the battery, please fully charge it before first use.

1. Unpacking and taking out the tool, correctly install the battery pack into the battery interface of the lithium secateurs.
2. Briefly press the unlock button on the switch, the indicator light is red, release the button you'll hear a "drip" sound which means the tool started normally, the first layer of protection is released. Then pull the trigger twice continuously, and the buzzer will make a "drip" sound again. At this time, the second layer of protection is released, the tool enters the activated state and can operate normally.
3. When the tool enters the activated state:

**For Normal Shearing:** Press the trigger, the blade closes, release the trigger, the blade opens.

**Opening Size Adjustment:** When the tool is in the normal activation state, press the trigger continuously until the buzzer gives a "drip" sound, then release the trigger. At this time, the opening size of the blade can be adjusted. Repeat the above operations can make new adjustments.

**Closing The Blades:** When the tool is in the normal activation state, press the trigger continuously until the buzzer gives a "drip" sound. Release the trigger after two "drips" sound. At this time, the blade is in the closed standby state. Pull the trigger twice continuously, after two "drips" sound, the blade will open to enter the activation state.

**NOTE:** If there is no operation after the machine is started for 3mins, the tool will "drip" twice and enter the standby state. At this time, to activate the tool, please pull the trigger twice continuously; If there is no operation in 10mins, the tool will shut down automatically after a "drip" sound. Please restart it when using.

**NOTE:** Please wear appropriate clothes and work gloves in operation. Before each use, ensure that the tool runs normally without a damaged trigger. If not, please stop using and go to the designated maintenance point for maintenance. Please wear protective devices and operate properly to reduce the risk of injury.

## SHUTDOWN OPERATION

Please be sure to shut down the tool after using, that is, the operation steps of blade closing. After the blade is closed, briefly press the power switch until the indicator light off which means the tool shut down successfully.

Then please remove the battery pack and store it with the tool properly.

## BLADE ADJUSTMENT AND REPLACEMENT

It is necessary to adjust the blade gap or replace the blade when cutting becomes difficult due to the larger gap or the blunt blade.

**NOTE:** Please remove the battery pack before operation

## BLADE GAP ADJUSTMENT

Loosen the Torx pan head screw with a wrench, remove the locking pad, and turn the blade fixing nut to properly adjust the clearance to achieve the best pruning condition.

## BLADE DISASSEMBLY

1. Twist the screws counterclockwise and remove the side cover. (Fig. 1)
2. Twist the Torx pan head screw counterclockwise, remove the locking pad, and screw out the blade fixing nut counterclockwise (Fig. 2)
3. Take out the blade pin assembly and pin shaft, the movable blade can be removed after removing the swing gear (If it is impossible to disassemble, please ask professional personnel for help (Fig. 3))

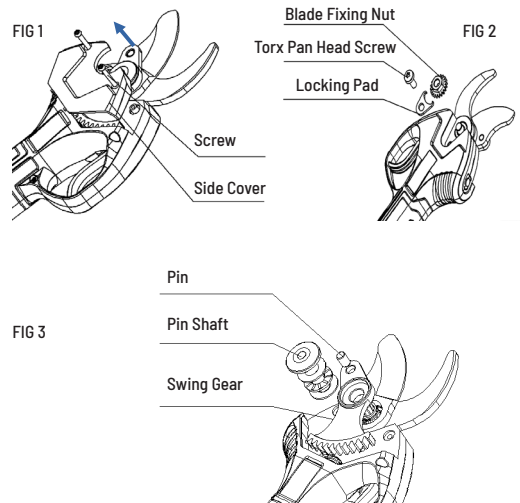

## BLADE INSTALLATION

1. Install the moving blade, swing gear, gasket, bearing, blade pin shaft and locating pin on the machine in turn, and add lubricating oil on the moving blade, fixed blade and blade pin shaft (Fig. 4)
2. Tighten the blade fixing nut clockwise (do not tighten too much here), install the locking pad, and tighten the Torx pan head screw clockwise (this screw should be tightened (Fig. 5)
3. Install the side cover and tighten the screws (Fig. 6)

FIG 4

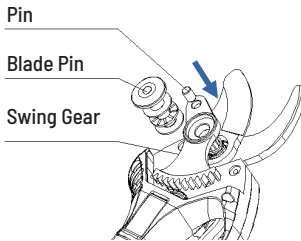

FIG 5

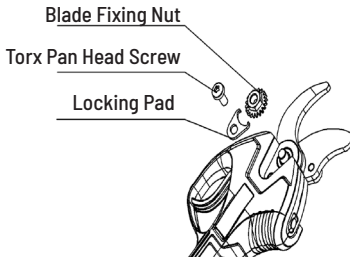
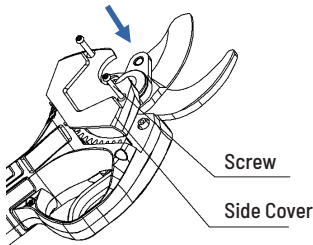

FIG 6



## GRINDING AND LUBRICATION OF BLADES

1. Blunt blade makes the shearing difficult. At this time, it is necessary to check the blade and add an appropriate amount of lubricating oil after grinding, otherwise the shear quality and service life of the blade will be affected.

The frequency of grinding depends on the characteristics of the sheared wood (hardness and diameter), pruning rate and grinding tool.

2. Add lubricating oil at least once after using 2 battery packs. Please refer to the figure below for the refueling method.

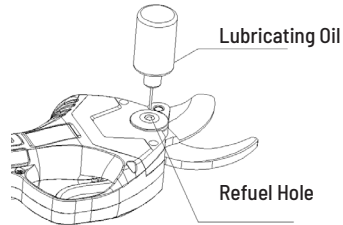

## SECATEURS PRECAUTIONS

1. Keep your other hand away from the cutting area of the blade during operation and do not put your hand into the blade opening.
2. The tool shall not be used to cut large branches, which may deform the blade and stuck the secateurs.
3. Please operate the tool strictly following the instructions, do not tilt it during shearing to avoid danger.
4. Necessary measures shall be taken to prevent the secateurs from getting stuck by the branches.
5. Please put the battery pack under waterproof clothes in cold or humid weather for protection. Do not use the equipment in rainy days.
6. Please disconnect the secateurs from the battery pack, turn off the power switch and store them together after daily use.

## ALARM WARNING

### BUZZER ALARMED

MOS Pipe Damaged - Failure indicator glitters 3 times  
Overcurrent- Failure indicator glitters 5 times  
Phase Loss - Failure indicator glitters 7 times  
Undervoltage or overvoltage - Failure indicator glitters 8 times  
Chip Overheating - Failure indicator glitters 9 times



## INSTALLING THE BATTERY

Please correctly insert the battery pack into the housing when installing as below pics show. Be sure to insert it to the bottom until you hear a "click", which indicates that the battery pack has been firmly installed on the chassis. Otherwise, the battery pack may accidentally fall off, resulting in injury to operators or others. Avoid inserting the battery pack with excessive force or knocking it in with the help of other objects.

**NOTE:** Only the battery pack of the specified model can be used. Other brands cannot well match the tools to work normally, and may damage the tools, resulting in accidental injury or fire.

## REMOVING BATTERY

Press the latch buttons on both sides of the battery pack housing inward, and then pull out the battery pack in the direction of the arrow shown in the figure.

**NOTE:** Do not force to haul out the battery pack.

1. Battery Indicator
2. After the "click", the latch buttons on both sides of the battery pack fully rebound back.

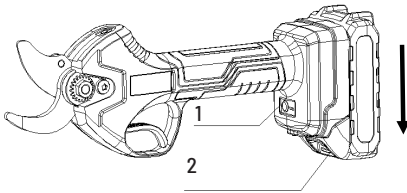

## BATTERY INDICATOR

After starting, the battery indicator will display the electricity amount by the status of three green LED lights (hereinafter referred to as green lights)

Three lights on = The electricity amount > 66%  
Two lights on = The electricity amount 33-66%  
One light on: The electricity amount < 33%  
Light glitters: Under voltage and about to power off.

**NOTE:** When the failure indicator glitters for protection, the battery pack will stop working until the protection released. Then the tool can be started normally.

## CHARGING METHOD

The charger is suitable for charging lithium-ion batteries of specified models under general environmental conditions.

Inserting the charger plug into the power socket, the green light will be on which means entering the charging waiting state, then connect the charging connector with the battery pack, charging begins. During charging, the indicator light turns to red, and shall turn back to green after fully charged.

The charger can detect a fault caused by the battery pack and judge it by the state of the indicator light. When fault occurs, re-insert the battery pack (not fully charged) into the charger. If the fault still exists, use another battery pack. If the new battery pack can charge normally, the original battery pack may be damaged. If the new battery pack still have the same problem, the charger may be damaged and needs to be tested and repaired.

Input Supply Voltage (AC)/V	100-240
Charging Current /A	1
Input Supply Frequency /HZ	50/60
Applicable Battery Voltage (DC)/V	16.8\21
Applicable Battery Capacity /Ah	2.0
Fully Charged Time	2.5 Hours

Light Indicator



# MAINTENANCE

## SIDE COVER CLEANING

Please remove the side cover and clean up the sun-dries inside after working continuously for 8 hours.

## INSPECTION FOR FIXING SCREWS

Please often check the stability of fixing screws, if the screws are loose, retighten them immediately to avoid accidents.

## CLEANING

Chemical cleaning agent or other liquids are forbidden to be used for cleaning the tool, please wipe it with a dry cloth.

## INSPECTION & REPAIR

Daily inspection shall be conducted by the keeper when the tool is sent out or taken back; the user shall also conduct the daily inspection before use.

The daily inspection shall at least include the following items:

1. Is there a regular inspection mark.
2. Whether the switch operates normally and flexibly, if there's any defects or cracks.
3. Whether the battery pack has liquid leakage, damage or other bad conditions.

The unit using tools shall equip with full-time personnel for regular inspection.

Please conduct the inspection at least once a year.

In hot and humid areas with frequent temperature changes or places with poor service conditions, the inspection cycle shall be shortened accordingly.

Please inspect in time before the rainy season.

The tools that pass the regular inspection shall have a "qualified" mark pasted on the appropriate position. The mark shall be distinct, clear, correct, and at least include:

1. Tool No.
2. Name or sign of the inspection unit.
3. Name or sign of the inspector.
4. Effective date.

Tools that are not used for a long time shall be carefully checked before use. Please use the tool after the inspection passed and the "qualified" mark pasted.

The maintenance of tools shall be carried out by the maintenance unit approved by the original production unit

The user and maintenance unit shall not arbitrarily modify the original design parameters of the tool, and shall not use substitute materials worse than the performance of raw materials and parts inconsistent with the original specifications.

For repaired tools, if inspected and tested qualified, the "qualified" mark shall be pasted at an appropriate position; For tools that cannot be repaired or still fail to meet the safety technical requirements after repair, scrapping procedures and isolation measures shall be taken.

## STANDARD ACCESSORIES

NOTE: Not all accessories shown on the drawings, tables or instructions are included in the supply scope.

Whetstone, Wrench T10, Wrench T30, Socket Wrench, Battery Pack, Charger, Lubricant, Tool Kit

This product is mainly used for pruning branches such as landscaping, municipal greening, forestry, orchard, farm and family gardening, etc.

## WARRANTY

Subject to the following conditions, this unit is covered by a comprehensive two-year warranty.

The unit is designed for domestic purposes only, issues and faults due to commercial use may not be covered by warranty. The warranty covers all manufacturing faults but excludes normal wear and tear, misuse, neglect, accidental damage or defects arising from failure to comply with instructions as outlined in this owners manual. Only genuine spare parts can be used for repairs and this must be carried out by an authorised LawnMaster Services Dealer to maintain warranty.

Warranty does not cover the cost of transportation of any part(s) but does cover the labour/parts cost incurred in repairing or replacing any defective part(s) consequential or special damages and / or expenses resulting from any defect.

If the unit requires further repairs or services please visit [www.lawnmaster.co.nz](http://www.lawnmaster.co.nz) to find your local LawnMaster Service Dealer.

For all other enquiries contact **Steeffort Customer Services +64 6 350 1350**

# LawnMaster®

## FIND US



[www.lawnmaster.co.nz](http://www.lawnmaster.co.nz)



lawnmasternz

### Steelfort

500 Rangitikei Street, Private Bag 11045  
Palmerston North, 4412, New Zealand  
06 350 1350

### Steelfort Auckland

880 Great South Road, Penrose  
Auckland, 1061, New Zealand  
09 573 1324